

TOWNSHIP OF MOON

INGROUND SWIMMING POOL

BUILDING PERMIT APPLICATION CHECKLIST

<input type="checkbox"/>	Fill out and sign the "Swimming Pool Application" form. Incomplete application can result in a denied permit. <u>Building permit fee is paid after approval and when it is picked up.</u>
<input type="checkbox"/>	Fill out the separate "Electrical Permit Application" and <u>Must include the electrical permit fee check, see electrical permit fee schedule,</u> payable to "Township of Moon".
<input type="checkbox"/>	Fill out and sign the "Permit Agreement" form.
<input type="checkbox"/>	Fill out and sign the "Workers Compensation Affidavit of Exemption" form OR Provide proof of Workers Compensation Insurance Certificate and name Moon Township as a certificate holder.
<input type="checkbox"/>	Fill out and sign the "Swimming Pool Affidavit" form.
<input type="checkbox"/>	Provide 2 copies of the "Property Survey Plot Plan". Add outline and location of the proposed swimming pool drawn to scale on the "Property Survey Plot Plan". Add fence and gates locations. Show dimensions from all 4 property lines to the proposed pool. Show location of safety barrier fence and gates. Gates must swing out. Show locations of all doors and grade level windows that require pool door/window alarms leading into the fenced in swimming pool area.
<input type="checkbox"/>	Provide details, plans, brochure, construction plan of the proposed pool.
<input type="checkbox"/>	Provide details, brochure, cut sheets if installing a swimming pool heater.
<input type="checkbox"/>	Provide details if installing a diving board and include diving water envelope section details.
<input type="checkbox"/>	Provide section view detail of proposed inground pools including water depth, bottom slope, side slope etc.
<input type="checkbox"/>	Provide details, brochure, cut sheets if installing a powered safety cover that complies with ASTM F1346.
<input type="checkbox"/>	Provide details, and specific code compliance dimensions of the proposed safety barrier fence and self-closing gate. Hardware and latch.
<input type="checkbox"/>	
<input type="checkbox"/>	
<input type="checkbox"/>	

All swimming pool, spa and hot tub installations shall comply with Pa State UCC adopted 2015 International Swimming Pool and Spa Code. ISPSC

Swimming pools and hot tubs and any related accessory structures are required to be set back 10' from the side and rear property lines. They are not permitted to be located in the front yard. The water's edge of a swimming pool and hot tub is required to be 6' away from any grade level non-tempered glass window, door etc.

Swimming pools and hot tubs cannot be located on a easement or right of way.

Any questions, email the Building Official, Dave Meinert, dmeinert@moontwp.us



TOWNSHIP OF MOON

1000 Beaver Grade Road, Moon Township, PA 15108
412.262.1700 ♦ moonntp.us

SWIMMING POOL, HOT TUB AND ZONING PERMIT APPLICATION

Location of Construction: _____
Street City State Zip

Applicant's Name: _____

Applicant's Phone No.: _____ Email: _____

Applicant's Address: _____
Street City State Zip

Type of Improvement: Aboveground Pool Inground Pool Hot Tub Other (specify) _____

Total Cost of Improvements: _____

Type of Use: Residential Commercial Industrial Other (specify) _____

Property Information:

Zoning District: _____ County Lot & Block No.: _____ Lot Size: _____

Subdivision Name: _____ Lot No.: _____

Owner's Name: _____

Owner's Phone No.: _____ Email: _____

Owner's Address: _____
Street City State Zip

Occupant's Name: _____ Occupant's Phone No.: _____

Zoning Setbacks (the distance between the structure and the property lines):

Front Yard: _____ Rear Yard: _____ Right Side: _____ Left Side: _____

Proposed Construction:

Size: _____ X _____

Pool Depth: _____ Diving Board

Contractor's Company Name: _____ Contact Person: _____

Contact Phone No.: _____ Email: _____

Contractor's Address: _____
Street City State Zip

The Applicant/Owner hereby certifies that the statements made herein and representations contained in all accompanying matter part of this application are true and correct. The Applicant/Owner shall be responsible for reviewing and fully understanding all permit conditions and insuring compliance to all applicable codes and ordinances. The Applicant/Owner shall also be responsible for any fees incurred in relation to the above project. The Applicant/Owner grants Moon Township Officials the right to enter onto the property for inspecting the work permitted and posting notices. As Applicant, I hereby certify that proposed work is authorized by the Owner of record and I have been authorized by the Owner to make this application as his authorize agent.

Applicant/Owner's Signature: _____

Date: _____

In considering of the issuance by the Township of Moon (the "Township") of a Building Permit, Zoning Permit and other permits for the property located at _____ and to the undersigned property Owner(s) or the Agent(s) (the "Applicant"), the Applicant acknowledges that, in reviewing plans and specifications, in issuing permits and inspection work of the Applicant; the employees, consultants, elected or appointed official of the Township are only performing their duties to require compliance with the minimum requirements of the applicable ordinances of the Township and the minimum requirements of the applicable ordinances of the Township and the Pennsylvania Uniform Construction Code pursuant to the police power of the Township and are not warranting to the Applicant or to any third party the quality of adequacy of the design, engineering or work of the Applicant or their agents or contractors.

Applicant further acknowledged that although plan review and inspections will be provided, it will not be possible for the Township to review every aspect of the Applicant's design and engineering or to inspect every aspect of the Applicant's work. Accordingly, neither the Township nor any of its elected appointed officials, consultants, or employees shall have any liability to the Applicant for defects or shortcomings in such design, engineering or work, even if it is alleged that such defects or shortcomings should have been discovered during the Township's review or inspection, Furthermore, the Applicant agrees to defend, hold harmless and indemnify the Township, its elected officials, consultants and employees from and against any and all claims, demands, actions, and causes of actions of any one or more third parties arising out of or relating to the Township's review or inspection of the Applicant's design, engineering, or work or issuance of a permit or permits, or arising out of or relating to the design, engineering or work done by Applicant pursuant to such permit or permits. All references in this Agreement to Applicant's design, engineering or work shall include such design, engineering, and work, which is performed by the Applicant or by the Applicant's employees, agents, independent contractors, subcontractors or any other person or entities performing work pursuant to the issuance of the Building Permit Zoning Permit and other permits by the Township.

Owner/Agent's Signature _____

Date _____

Print Name _____

SWIMMING POOL - HOT TUB AFFIDAVIT

TOWNSHIP OF MOON

As the owner and owner's agent and swimming pool contractor of the property located at (address of pool construction) _____

in Moon Township, Pennsylvania, I am aware of, and I have received a copy of the building permit checklist/requirements for the enclosure and safety devices of a swimming pool, hot tub, and spa in accordance with the PA Uniform Construction Code.

I am aware as the property owner and owner's agent and pool contractor, that the pool or spa shall be appropriately protected by a code compliant constructed fence or barrier during and after construction.

A swimming pool, hot tub, or spa shall not be used or occupied until Moon Township has granted all final electrical, mechanical and building inspections approvals.

All approved inspections and occupancy permit must be obtained prior to use of the swimming pool, hot tub.

Hot Tubs require the following inspections:

- Electrical rough and final inspections
- Final building inspection

Aboveground pools require the following inspections:

- Electrical rough and final inspections
- Final building inspection

Inground pools require the following inspections:

- Electrical rough and final inspections.
- Electrical bonding inspection before concrete is poured.
- Final building inspection including the pool, hot tub, door alarms, and gates, fence pool barrier.

I am aware that all future additional alterations, deck, swimming pool barrier fence, etc. always requires a building permit and compliance inspections.

Signature _____ Date _____

Name (please print) _____ Contact No. _____

WORKERS COMPENSATION AFFIDAVIT OF EXEMPTION

TOWNSHIP OF MOON

The undersigned swears or affirms that he/she is not required to provide workers' compensation insurance under the provisions of Pennsylvania's Workers' Compensation Act for one of the following reasons, as indicated:

- Contractor is a sole proprietorship with no employees.
- Religious exemption under Section 304.2 of the Workers' Compensation Law.
- Contractor is a corporation and the only employees working on the project have and are qualified as "Executive Employees" under Section 104 of the Workers' Compensation Act. Please explain:

- Owner is the Contractor
- Other: Please explain: _____

Please be aware of the following requirements under the Pennsylvania Workers' Compensation Act:

1. Any subcontractors used on this project will be required to carry their own workers' compensation coverage.
2. Violation of the Worker's Compensation Act or the terms of this information form will subject the Contractor to a stop-work order and other fines and penalties as provided by law.

My signature on behalf of or as the Contractor as stated on this form constitutes my verification that the statements contained here are true.

Signature _____ Date _____

Name (please print) _____ Contact No. _____

Address: _____

ELECTRICAL PERMIT APPLICATION CHECKLIST

MOON TOWNSHIP, 1000 BEAVER GRADE RD, MOON TOWNSHIP, PA 15108 412-262-1700

<input type="checkbox"/>	FILL OUT AND SIGN THE "ELECTRICAL PERMIT APPLICATION" FORM.
<input type="checkbox"/>	FILL OUT AND CALCULATE FEE ON THE "ELECTRICAL PERMIT FEE WORKSHEET".
<input type="checkbox"/>	ADD UP ALL FEES IN THE COLUMN TO THE TOTAL FEE
<input type="checkbox"/>	FEE CHECK FOR TOTAL AMOUNT MADE TO "MOON TOWNSHIP".
<input type="checkbox"/>	SUBMIT "ELECTRICAL PERMIT APPLICATION" AND "ELECTRICAL PERMIT FEE WORKSHEET" AND FEE PAYMENT CHECK MADE TO MOON TOWNSHIP ALL IN HARD COPY TO THE MOON TOWNSHIP OFFICE
<input type="checkbox"/>	
<input type="checkbox"/>	
<input type="checkbox"/>	
<input type="checkbox"/>	

-
- Electrical permit fee check must be submitted together with the Electrical Permit Application and the Electrical Permit Fee Worksheet.
 - Contact the electrical inspector to schedule electrical inspections at, Electrical Inspector, John Panek, 412-974-5445.

TOWNSHIP OF MOON

1000 Beaver Grade Road, Moon Township, PA 412-262-1700

Permit No. _____

ELECTRICAL PERMIT APPLICATION

Job Address: _____

Subdivision: _____ Property Lot #: _____

Applicant: _____ Applicant Phone #: _____

Applicant Email: _____

Property Owner: _____

Property Owner Address: _____

Property Owner Phone #: _____

Electrician's Name: _____ Electrician's Phone #: _____

Electrician's Address: _____ City: _____

Type of Improvement: New Construction Addition Alterations

Other: _____

Description of Work:

The Applicant/Owner hereby certifies that the statements made herein, and representations contained in all accompanying matter part of this application are true and correct. The Applicant/Owner shall be responsible for reviewing and fully understanding all permit conditions and ensuring compliance with all applicable Codes and Ordinances. The Applicant/Owner shall also be responsible for any fees incurred (engineering, etc.) in relation to the above proposed project. The Applicant/Owner grants Moon Township officials the right to enter onto the property for the purpose of inspecting the work permitted and posting notices. As an applicant, I hereby certify that proposed work is authorized by the Owner of Record, and I have been authorized by the Owner to make this application as his authorized agent.

Applicant/Owner's Signature _____ Date: _____

Call Electrical Inspector to schedule your inspection - Electrical Inspector - John Panek 412-974-5445

*****All Electrical Permit Applications MUST be accompanied with the completed Electrical Permit Fee Worksheet and a check made payable to "Township of Moon" *****

Office Use Only

Permit Fee

Check No./ Receipt No.

Permit Approved by

TOWNSHIP OF MOON

1000 Beaver Grade Road, Moon Township, PA 412-262-1700

RESIDENTIAL ELECTRICAL PERMIT FEE WORKSHEET

Item Description	Qty		Fee	Total
1.) Re-inspection Fee, Additional Inspection Fee and Minimun Trip Fee		X	\$150	
2.) Residential Flat Rate, New Construction up to 400A		X	\$400	
3.) Residential Additions and Alterations (<i>Two Inspections</i>)		X	\$350	
4.) Services and Subpanels up to 200A (<i>One Inspection</i>)		X	\$150	
5.) Residential Alterations up to 15 Outlets and Services to 200A (<i>One Inspection</i>)		X	\$200	
6.) Hot Tubs (<i>One Inspection</i>)		X	\$150	
7.) Aboveground Swimming Pools (<i>One Inspection</i>)		X	\$250	
8.) Inground Swimming Pools (<i>Two Inspections</i>) <i>(Swimming Pool panels and/or pool houses are extra, use above fees)</i>		X	\$350	
9.) Photo Voltaic Systems		X	\$350	
10.) Solar array battery backup, power wall		X	\$150	
11.) Electric vehicle Chargers		X	\$200	
12.) Temporary construction service		X	\$150	
13.) Deck / Patio / Porch		X	\$250	
			Flat State Fee	\$4.50
			Total	

All Commercial Electrical Permit Applications **MUST** include this worksheet and a payment fee check, made to Township of Moon, in the total amount calculated.

Job Address _____

Sign and Print Name _____ Date _____

Electrician/Electrical Design Professional

Sign and Print Name _____ Date _____

Applicant

ELECTRICAL WIRING REQUIREMENTS FOR ABOVE GROUND SWIMMING POOLS

ANY POOL CAPABLE OF HOLDING WATER TO A DEPTH GREATER THAN 42in IS TO BE CONSIDERED A PERMANENTLY INSTALLED POOL. 2014 NEC Article 680.2 definitions.

Pool Pump Receptacle (Outlet) and Wiring Method

Receptacle(s) that provide power for water-pump motors or for other loads directly related to the circulation and sanitation system that are located within 6FT - 10FT measured horizontally from the inside pool wall, if they meet the following conditions:

1. Consist of a single receptacle. *Note: Newer NEC does not require a single device*
2. Are of the grounding type.
3. Have GFCI protection.

Receptacles must have an (in-use) weatherproof cover that can be closed when inserted and be Tamper-resistant (TR) and weather-resistant (WR).

Conductors for pool - associated motors shall be installed in rigid metal conduit, intermediate metal conduit, rigid nonmetallic conduit (PVC), or Type MC cable ~~listed for~~ swimming pools. Any wiring method employed shall contain an insulated copper equipment-grounding conductor sized in accordance with 250.122 but not smaller than 12 AWG.

Single Family Dwellings – In the interior of dwelling units or accessory buildings associated with a dwelling unit any of the wiring methods recognized in Chapter 3 of N.E.C. that comply with the provisions of this section shall be permitted. Cable assembly with uninsulated grounding conduction permitted where enclosed within the outer sheath or cable assembly. Example - NMC (non-metallic cable) (Romex) permitted.

Conversion of interior wiring method to exterior wiring, with insulated and weather resistant conductors, shall be spliced in an interior junction box to change over to exterior wiring methods. NMC not permitted for exterior wiring method.

The pump motor cord-and-plug that comes with the pump MAYBE for testing purposes only. (Read the tag on the pump cord.)

If it is not a listed cord-and-plug, you must purchase a Cord & Plug set with a #12 insulated grounding conductor listed for wet locations. The Cord & Plug shall not exceed 3FT in length.

See Article 680.21 (5).

The equipment-grounding conductor shall be insulated and green in color.

Article 680.21(A) (1) of the NEC specifies that the grounding conductor for the pool pump must be insulated and sized according to Article 250.119 & 122, which identifies it to be green in color throughout its entire length. **(Therefore, YOU CANNOT USE UF CABLE FOR THE POOL PUMP.)** It does not employ a *green insulated* equipment-grounding conductor but instead a bare equipment grounding conductor.

Article 310.10(C) specifies the type of conductors for wet locations.

They shall be any of the below listed types: TW, THW, THW-2, THHW, THHW-2, THWN, THWN-2, etc. No other wiring is permitted within 5FT measured horizontally from the pool unless it is absolutely necessary to supply the pool and associated equipment. Article

680.10.

The branch circuit conductors listed above and the raceways must be buried at least 18¹N deep. They can be buried 12ⁱⁿ deep based on Table 300.5, Column 4 of the 2014 NEC. Exception: 1&2 Family dwellings when rated 120 Volts or Less with GFCI Protection and a maximum overcurrent protection of 20 Amperes .

Metal - All Rigid Metal Conduit must be buried no less than 6ⁱⁿ deep.

Convenience Receptacle(s) {See *Note In the Quick Review}

At least one (1) **Tamper-resistant (TR) /Weather-resistant (WR) convenience** receptacle, other than the pool pump receptacle, must be installed between 5FT minimum and 20FT maximum, measured from the inside wall of the pool. This receptacle shall be located not more than 6FT 6ⁱⁿ above the floor, platform, or grade level serving the pool.

Convenience receptacle(s) must be GFCI protected, Tamper-resistant and weather-resistant. Must have an in-use weatherproof cover where exposed to the weather.

Wiring Method: **(YOU CAN USE UF CABLE FOR THE CONVENIENCE RECEPTACLE.)**

(If installing the pump receptacle conductors and convenience receptacle conductors in the same raceway, all conductors must be GFCI protected. No exceptions.)

UF cable Rated 120 Volts or Less, that is GFCI protected and that has a maximum overcurrent protection of 20 Amperes or less based on Table 300.5, Column 4 of the 2014 NEC can be buried at least 12ⁱⁿ deep.

UF cable not GFCI Protected must be buried 18ⁱⁿ deep.

Metal - All Rigid Metal Conduit must be buried no less than 6ⁱⁿ deep.

Bonding The Pool

All metal parts must be bonded together using a #8 (or larger) solid copper wire with approved fittings. All metal fences 5FT or less must be bonded. Bonding requires the pump, the metal frame of the pool, the water, bonding ring around the pool (18ⁱⁿ from the pool wall and a 4in to 6ⁱⁿ deep trench) or anything metal within 5FT. You must use LISTED non-corrosive clamps. (i.e.: Copper or stainless steel - lugs, split bolts etc.) **YOU DO NOT NEED TO INSTALL A GROUND ROD.** This is for pool bonding NOT grounding.

Quick Review - Refer to the Illustration.

Receptacles in Weatherproof boxes with an "in-use covers".

The minimum depth of trench: 18ⁱⁿ deep. It can be 12ⁱⁿ deep for 1 & 2 Family dwellings based on Table 300.5. Conductor types are: THWN, XHHN, or other approved conductors. (See Article 310.10(C).) They are to be Black, Red, blue, orange, yellow, purple, or other color to identify the ungrounded conductor, white or grey for the grounded conductor and green for the insulated equipment conductor.

You CAN re-identify any color conductor for the ungrounded conductor (hot) but the grounded conductor (neutral) must be white, or have white and gray strips continuous throughout its entire length. See Article 200.6) But you CANNOT re-identify the equipment grounding conductor. It must be green throughout its entire length. DO NOT use green tape. (See Article 250.119)

Convenience receptacle GFCI protected in a Weatherproof box with an "in-use cover." ***Note.** If you have an existing GFCI within 20FT this counts as the convenience receptacle.

At least one Convenience receptacle must be installed using UF cable or other approved wiring method. The trench can be a minimum of 12ⁱⁿ deep when rated 120 Volts or less with GFCI protection and a maximum overcurrent protection of 20 Amperes. NEC Table 300.5, Column 4. (For 12ⁱⁿ burial depth, the conductors must be GFCI protected at the house, if they are not GFCI protected, the burial depth must be at least 18ⁱⁿ.)

Minimum #8 solid copper conductor for bonding purposes.

The above swimming pool rules are based on the 2014 National Electrical Code. Some rules are paraphrased for clarification. This is not a comprehensive description. It is only a guide.

Please refer to the 2014 NEC, Article 680 and other related articles.

Above Ground Pool - For Illustrated Purposes Only

Your situation may be different - Refer to 2014 NEC Article 680

All receptacles must be GFCI protected, have in-use Weather-Resistant Covers and be both Tamper-Resistant and Weather-Resistant. The pump should be located so the cord & plug can be inserted with some slack.

PUMP TIMER REQUIRED BY PA ENERGY CODES

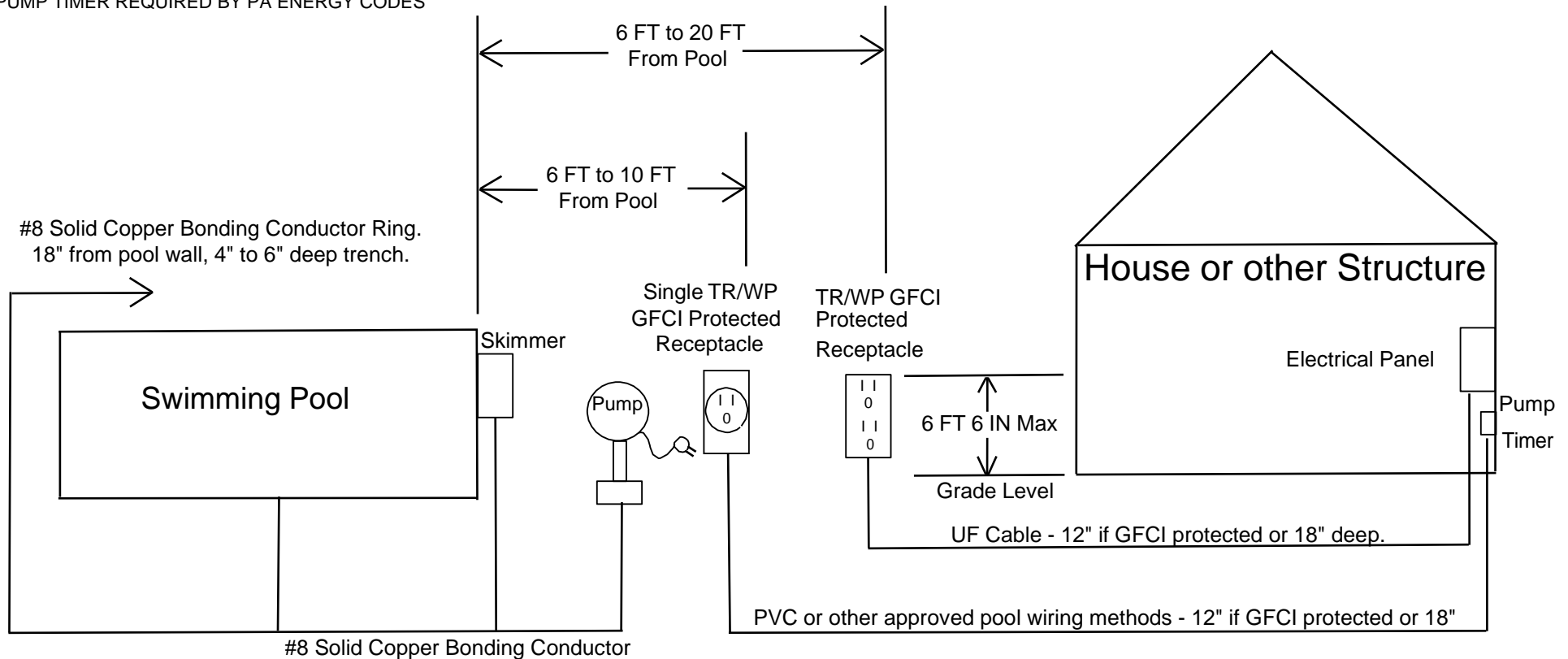

Metal frame of pool and skimmer or other approved means to bond the water. The bonding is not required to go to the electrical panel.

CODE REQUIREMENTS FOR SWIMMING POOLS

Localities in Pennsylvania enforce the regulations established by the Pennsylvania Uniform Construction Code, PA UCC regarding the installation, use and maintenance of all swimming pools, hot tubs and spas for both private and public residential and commercial pools.

No persons shall begin construction of a swimming pool nor substantially alter or reconstruct any swimming pool without having first submitted construction plans and specifications to the local building department for review and approval. No work shall be commenced until having first obtained the required permits for the pool, electrical work, mechanical work and fence or barrier protection as required by the regulations.

It is unlawful for any person to construct, maintain, use, possess or control any swimming pool not properly protected by a permanent fence or barrier in accordance with the regulations regardless of the date of construction. Any person who shall violate any provisions of the regulations may be subject to legal action as allowed by the PA UCC.

PERMITS:

A building permit is required for installing all new pools, hot tubs, and spas. An electrical permit is required for any electrical circuits or electrical work added for the pool and a gas or mechanical permit is required for pool heaters or other mechanical equipment for the pool.

The property owner is responsible for ensuring the pool is properly protected by a fence or barrier meeting code requirements during construction and after completion and approval. In addition, any fence erected must be constructed with the "finished side" facing outward towards surrounding properties or right-of-way.

PA ONE CALL SYSTEM

STOP-CALL BEFORE YOU DIG

CALL PA ONE CALL BEFORE YOU DIG 1-800-242-1776

Many communities have enacted safety regulations for barriers at residential swimming pools—in ground and above ground. In addition to following these laws, parents who own pools can take their own precautions to reduce the chances of their youngsters accessing the family or neighbors' pools or spas without supervision. This booklet provides tips for creating and maintaining effective barriers to pools and spas.



Each year, thousands of American families suffer swimming pool tragedies—drownings and near-drownings of young children. The majority of deaths and injuries in pools and spas involve young children ages 1 to 3 and occur in residential settings. These tragedies are preventable.

This U.S. Consumer Product Safety Commission (CPSC) booklet offers guidelines for pool barriers that can help prevent most submersion incidents involving young children. This handbook is designed for use by owners, purchasers, and builders of residential pools, spas, and hot tubs.

The swimming pool barrier guidelines are not a CPSC standard, nor are they mandatory requirements. CPSC believes that the safety features recommended in this booklet will help make pools safer, promote pool safety awareness, and save lives. Barriers are not the sole method to prevent pool drowning of young children and cannot replace adult supervision.

Some states and localities have incorporated these guidelines into their building codes. Check with your local authorities to see what is required in your area's building code or in other regulations.



Swimming Pool Barrier Guidelines

Many of the nearly 300 children under 5 who drown each year in backyard pools could be saved if homeowners completely fenced in pools and installed self-closing and self-latching devices on gates.

Anyone who has cared for a toddler knows how fast young children can move. Toddlers are inquisitive and impulsive and lack a realistic sense of danger. These behaviors make swimming pools particularly hazardous for households with young children.

CPSC reports that child drownings are the second leading cause of accidental death around the home for children under 5 years of age. In some southern or warm weather states, drowning is the leading cause of accidental death in the home for children under 5.

CPSC staff has reviewed a great deal of data on drownings and child behavior, as well as information on pool and pool barrier construction. The staff concluded that the best way to reduce child drownings in residential pools is for pool owners to construct and maintain barriers that will help to prevent young children from gaining access to pools and spas.

The guidelines provide information for pool and spa owners to use to prevent children from entering the pool area unaccompanied by a supervising adult. They take into consideration the variety of barriers (fences) available and where each might be vulnerable to a child wanting to get on the other side.

The swimming pool barrier guidelines are presented with illustrated descriptions of pool barriers. The definition of pool includes spas and hot tubs. The swimming pool barrier guidelines therefore apply to these structures as well as to above ground pools, and may include larger portable pools.

Pool and Spa Submersions: Estimated Injuries and Reported Fatalities*

CPSC publishes an annual report on submersion incidents. Key findings from the 2012 report include:

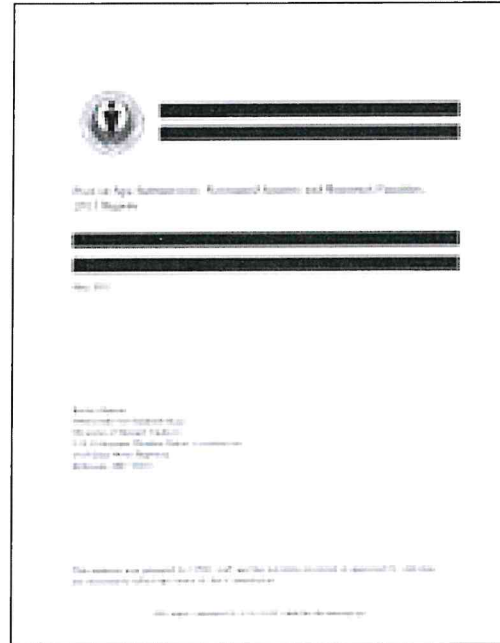

- Nearly 300 children younger than 5 drown in swimming pools and spas each year representing 75 percent of the 390 fatalities reported for children younger than 15.
- Children aged 1 to 3 years (12 months through 47 months) represented 67 percent of the reported fatalities and 66 percent of reported injuries in pools and spas.
- Over 4,100 children younger than 5 suffer submersion injuries and require emergency room treatment; about half are seriously injured and are admitted to the hospital for further treatment.
- The majority of drownings and submersion injuries involving victims younger than 5 occur in pools owned by the family, friends or relatives.
- The majority of estimated emergency department-treated submersion injuries and reported fatalities were associated with pools.
- Portable pools accounted for 10 percent of the total fatalities (annual average of 40) for children younger than 15.

**The report presents average annual estimates for emergency department-treated injuries for 2009 through 2011 and average annual estimates for fatal submersions for 2007 through 2009, as reported to CPSC staff. The years for reported injury and fatality statistics differ due to a lag in fatality reporting.*



Barriers

Barriers are not child proof, but they provide layers of protection for a child when there is a lapse in adult supervision. Barriers give parents additional time to find a child before the unexpected can occur.

Barriers include a fence or wall, door alarms for the house, and a power safety cover over the pool. Use the following recommendations as a guide.

Barrier Locations

Barriers should be located so as to prohibit permanent structures, equipment or similar objects from being used to climb the barriers.

Fences

A fence completely surrounding the pool is better than one with the house serving as the fourth side. Fences should be a minimum of 4 feet high, although fences 5 feet or higher are preferable.

If the home serves as one side of the barrier install **door alarms** on all doors leading to the pool area. Make sure the doors have self-closing and self-latching devices or locks beyond the reach of children to prevent them from opening the door and gaining access to the pool.

Pool covers add another layer of protection and there are a wide variety of styles on the market. Keep pool covers well-maintained and make sure the control devices are kept out of the reach of children.

A successful pool barrier prevents a child from getting **OVER, UNDER, or THROUGH** and keeps the child from gaining access to the pool except when supervising adults are present.

How To Prevent a Child from Getting OVER a Pool Barrier

A young child can get over a pool barrier if the barrier is too low or if the barrier has handholds or footholds to use when climbing. The top of a pool barrier should be at least 48 inches above grade, measured on the side of the barrier which faces away from the swimming pool. Some states, counties or municipalities require pool barriers of 60 inches.

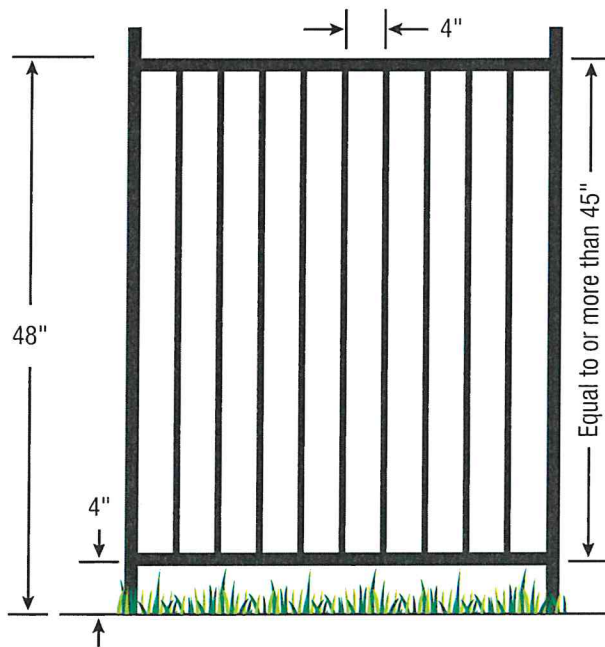

Figure 1

Eliminate handholds and footholds and minimize the size of openings in a barrier's construction.

For a Solid Barrier

No indentations or protrusions should be present, other than normal construction tolerances and masonry joints.

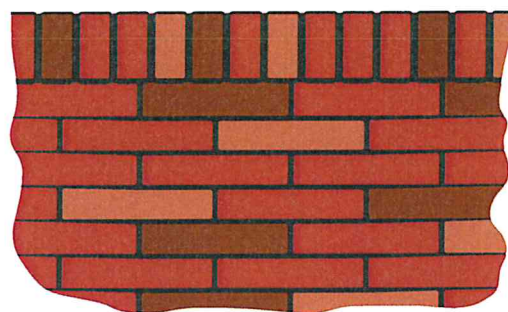
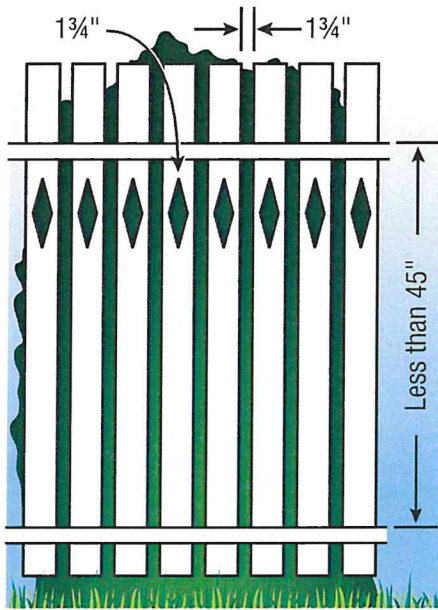

Figure 2

For a Barrier (Fence) Made Up of Horizontal and Vertical Members

If the distance between the top side of the horizontal members is less than 45 inches, the horizontal members should be on the swimming pool side of the fence.



The spacing between vertical members and within decorative cutouts should not exceed $1\frac{3}{4}$ inches. This size is based on the foot width of a young child and is intended to reduce the potential for a child to gain a foothold and attempt to climb the fence.

Figure 3

If the distance between the tops of the horizontal members is more than 45 inches, the horizontal members can be on the side of the fence facing away from the pool. The spacing between vertical members should not exceed 4 inches. This size is based on the head breadth and chest depth of a young child and is intended to prevent a child from passing through an opening. If there are any decorative cutouts in the fence, the space within the cutouts should not exceed $1\frac{3}{4}$ inches.

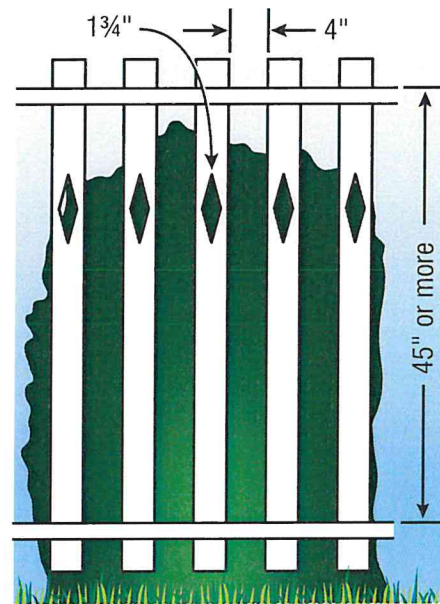

Figure 4

For a Chain Link Fence

The mesh size should not exceed $1\frac{1}{4}$ inches square unless slats, fastened at the top or bottom of the fence, are used to reduce mesh openings to no more than $1\frac{3}{4}$ inches.

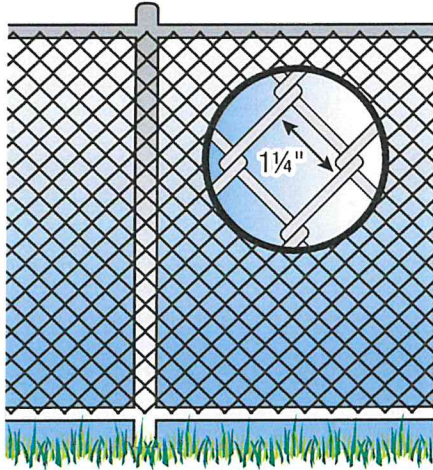

Figure 5

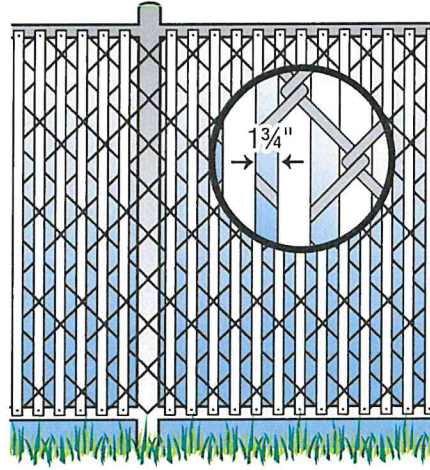

Figure 6

For a Fence Made Up of Diagonal Members or Latticework

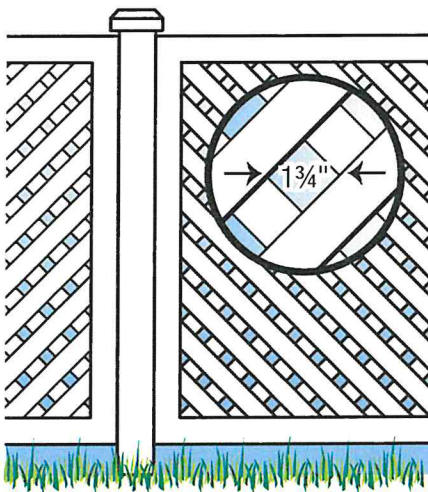

Figure 7

The maximum opening in the lattice should not exceed $1\frac{3}{4}$ inches.

For Above Ground Pools

Above ground pools should have barriers. The pool structure itself serves as a barrier or a barrier is mounted on top of the pool structure.

There are two possible ways to prevent young children from climbing up into an above ground pool. The steps or ladder can be designed to be secured, locked or removed to prevent access, or the steps or ladder can be surrounded by a barrier such as those described in these guidelines

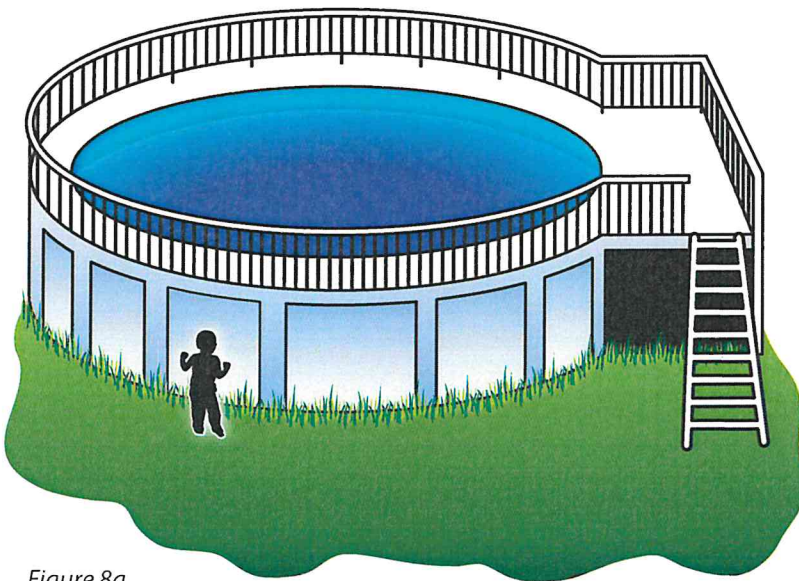

Figure 8a

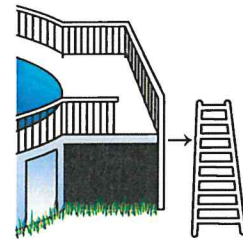

Figure 8b



Figure 8c

Above Ground Pool with Barrier on Top of Pool

If an above ground pool has a barrier on the top of the pool, the maximum vertical clearance between the top of the pool and the bottom of the barrier should not exceed 4 inches.

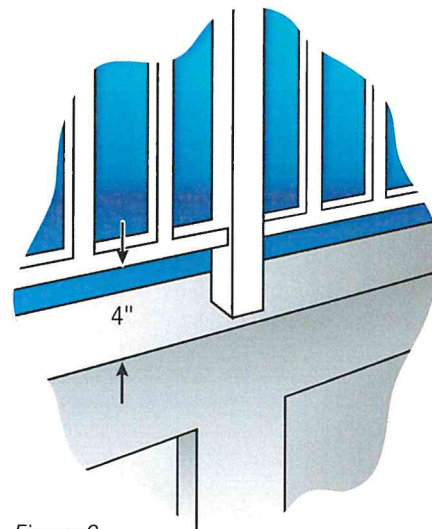

Figure 9

How to Prevent a Child from Getting UNDER a Pool Barrier

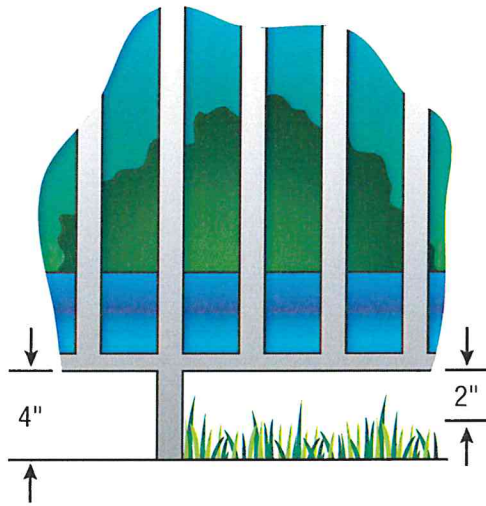

Figure 10

For any pool barrier, the maximum clearance at the bottom of the barrier should not exceed 4 inches above the surface or ground when the measurement is done on the side of the barrier facing away from the pool. Industry recommends that if the bottom of the gate or fence rests on a non-solid surface like grass or gravel, that measurement should not exceed 2 inches.

How to Prevent a Child from Getting THROUGH a Pool Barrier

Preventing a child from getting through a pool barrier can be done by restricting the sizes of openings in a barrier and by using self-closing and self-latching gates.

To prevent a young child from getting through a fence or other barrier, all openings should be small enough so that a 4-inch diameter sphere cannot pass through. This size is based on the head breadth and chest depth of a young child.

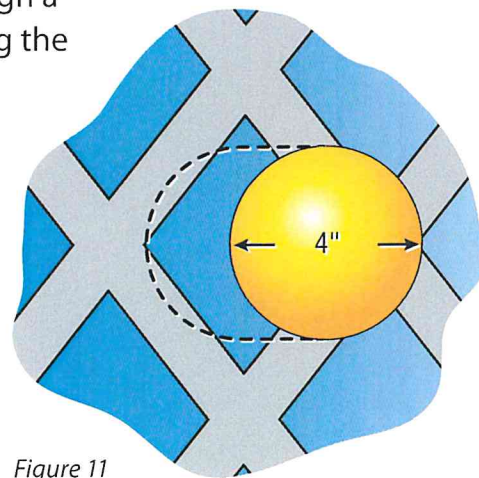

Figure 11

Portable Pools



Portable pools are becoming more popular. They vary in size and height, from tiny blow-up pools to larger thousands-of-gallons designs. Portable pools present a real danger to young children.

Never leave children unsupervised around portable pools. It is recommended that portable pools be fenced, covered or emptied and stored away. Instruct neighbors, friends and caregivers about their presence and the potential dangers of a portable pool in your yard.

Removable Mesh Fences

Mesh fences are specifically made for swimming pools or other small bodies of water. Although mesh fences are meant to be removable, the safest mesh pool fences are locked into the deck so that they cannot be removed without the extensive use of tools.



Like other pool fences, mesh fences should be a minimum of 48" in height. The distance between vertical support poles and the attached mesh, along with other manufactured factors, should be designed to hinder a child's ability to climb the fence. The removable vertical support posts should extend a minimum of 3 inches below grade and they should be spaced no greater than 40 inches apart. The bottom of the mesh barrier should not be more than 1 inch above the deck or installed surface.

For more information on Removable Mesh Fencing see ASTM standard F 2286 – 05.

Gates

There are two kinds of gates which might be found on a residential property: pedestrian gates and vehicle or other types of gates. Both can play a part in the design of a swimming pool barrier. All gates should be designed with a locking device.

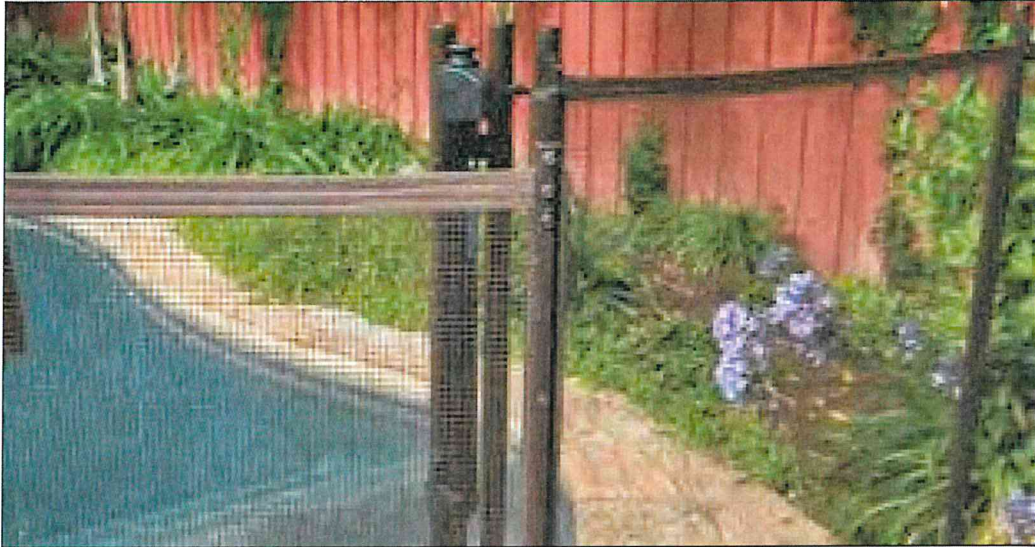

Pedestrian Gates

These are the gates people walk through. Swimming pool barriers should be equipped with a gate or gates which restrict access to the pool.

Gates should open out from the pool and should be self-closing and self-latching. If a gate is properly designed and not completely latched, a young child pushing on the gate in order to enter the pool area will at least close the gate and may actually engage the latch.



Figure 12

The weak link in the strongest and highest fence is a gate that fails to close and latch completely. For a gate to close completely every time, it must be in proper working order.

When the release mechanism of the self-latching device on the gate is less than 54 inches from the bottom of the gate, the release mechanism for the gate should be at least 3 inches below the top of the gate on the side facing the pool. Placing the release mechanism at this height prevents a young child from reaching over the top of a gate and releasing the latch.

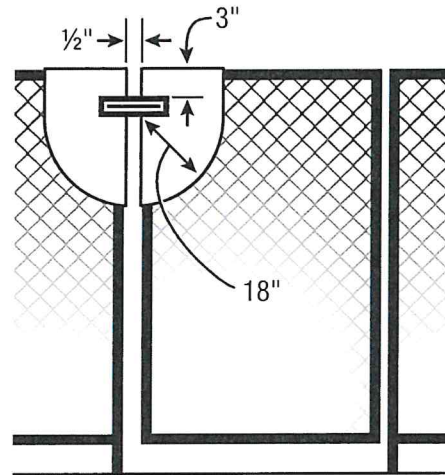
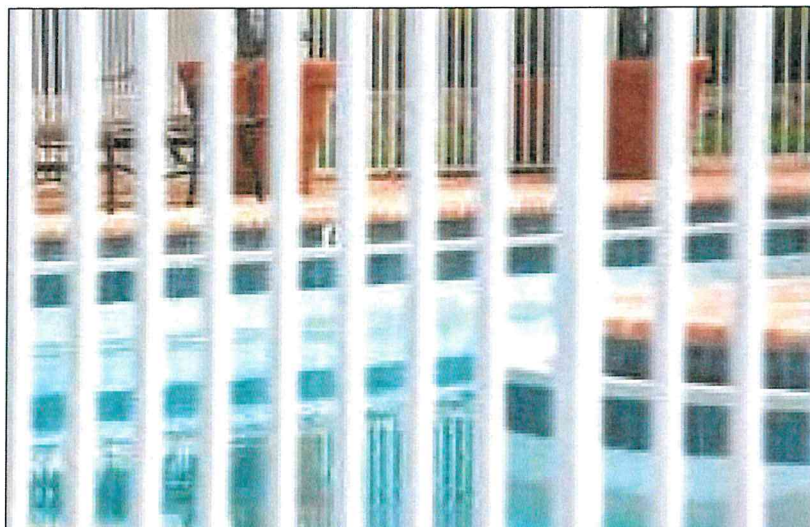

Figure 13

Also, the gate and barrier should have no opening greater than 1/2 inch within 18 inches of the latch release mechanism. This prevents a young child from reaching through the gate and releasing the latch.

All Other Gates (Vehicle Entrances, Etc.)

Other gates should be equipped with self-latching devices. The self-latching devices should be installed as described for pedestrian gates.



When the House Forms Part of the Pool Barrier

In many homes, doors open directly from the house onto the pool area or onto a patio leading to the pool. In such cases, the side of the house leading to the pool is an important part of the pool barrier. Passage through any door from the house to the pool should be controlled by security measures.

The importance of controlling a young child's movement from the house to pool is demonstrated by the statistics obtained in CPSC's submersion reports. Residential locations dominate in incidents involving children younger than 5 accounting for 85% of fatalities and 54 percent of injuries (from CPSC's 2012 *Pool and Spa Submersion Report*, see page 3).



Figure 14

Door Alarms

All doors that allow access to a swimming pool should be equipped with an audible alarm which sounds when the door and/or screen are opened. Alarms should meet the requirements of *UL 2017 General-Purpose Signaling Devices and Systems, Section 77* with the following features:

- Sound lasting for 30 seconds or more within 7 seconds after the door is opened.
- The alarm should be loud: at least 85 dBA (decibels) when measured 10 feet away from the alarm mechanism.
- The alarm sound should be distinct from other sounds in the house, such as the telephone, doorbell and smoke alarm.
- The alarm should have an automatic reset feature to temporarily deactivate the alarm for up to 15 seconds to allow adults to pass through house doors without setting off the alarm. The deactivation switch could be a touchpad (keypad) or a manual switch, and should be located at least 54 inches above the threshold and out of the reach of children.

Self-closing doors with self-latching devices could be used in conjunction with door alarms to safeguard doors which give access to a swimming pool.

Pet or Doggy Doors

Never have a pet or doggy door if the door leads directly to a pool or other backyard water. An isolation barrier or fence is the best defense when pet doors are installed. Remember, pet door openings, often overlooked by adults, provide curious children with an outlet to backyard adventure. Locking these doors is not sufficient and could lead to accidents and tragedies. Children regularly drown in backyard pools, which they were able to access through pet doors. Some municipalities have building codes that prohibit doggy doors in homes with pools unless there is an isolation fence around the pool.

Power Safety Covers

Power safety covers can be installed on pools to serve as security barriers, especially when the house serves as the fourth wall or side of a barrier. Power safety covers should conform to the specifications in the *ASTM F 1346-91 standard*, which specifies safety performance requirements for pool covers to protect young children from drowning.



Figure 15

Indoor Pools

When a pool is located completely within a house, the walls that surround the pool should be equipped to serve as pool safety barriers. Measures recommended for using door alarms, pool alarms and covers where a house wall serves as part of a safety barrier also apply for all the walls surrounding an indoor pool.

Barriers for Residential Swimming Pool, Spas, and Hot Tubs

The preceding explanations of CPSC's pool barrier guidelines were provided to make it easier for pool owners, purchasers, builders, technicians, and others to understand and apply the guidelines to their particular properties or situations. Reading the following guidelines in conjunction with the diagrams or figures previously provided may be helpful. For further information, consult your local building department or code authority.

Outdoor Swimming Pools

All outdoor swimming pools, including inground, above ground, or onground pools, hot tubs, or spas, should have a barrier which complies with the following:

1. The **top of the barrier** should be at least 48 inches above the surface measured on the side of the barrier which faces away from the swimming pool (figure 1).
2. The maximum **vertical clearance between the surface and the bottom of the barrier** should be 4 inches measured on the side of the barrier which faces away from the swimming pool. In the case of a non-solid surface, grass or pebbles, the distance should be reduced to 2 inches, and 1 inch for removable mesh fences (figures 1 and 10).
3. Where the top of the **pool structure is above grade or surface**, such as an above ground pool, the barrier may be at ground level, such as the pool structure, or mounted on top of the pool structure. Where the barrier is mounted on top of the pool structure, the maximum vertical clearance between the top of the pool structure and the bottom of the barrier should be 4 inches (figure 9).
4. **Openings in the barrier** should not allow passage of a 4-inch diameter sphere (figure 11).
5. **Solid barriers**, which do not have openings, such as a masonry or stone wall, should not contain indentations or protrusions except for normal construction tolerances and tooled masonry joints (figure 2).
6. Where the barrier is composed of **horizontal and vertical members** and the distance between the bottom and top horizontal members is less than 45 inches, the horizontal members should be located on the swimming pool side of the fence (figure 3).
7. **Spacing between vertical members** should not exceed 1¾ inches in width. Where there are decorative cutouts, spacing within the cutouts should not exceed 1¾ inches in width (figure 4).
8. **Maximum mesh size for chain link fences** should not exceed 1¼ inch square unless the fence is provided with slats fastened at the top or the bottom which reduce the openings to no more than 1¾ inches (figures 5 and 6).
9. Where the barrier is composed of **diagonal members**, such as a lattice fence, the maximum opening formed by the diagonal members should be no more than 1¾ inches (figure 7).
10. **Access gates** to the pool should be equipped with a locking device. Pedestrian access gates should open outward, away from the pool, and should be self-closing and have a self-latching device (figure 12). Gates other than pedestrian access

- gates should have a self-latching device. Where the release mechanism of the **self-latching device** is located less than 54 inches from the bottom of the gate,
- (a) the release mechanism should be located on the pool side of the gate at least 3 inches below the top of the gate and
 - (b) the gate and barrier should have no opening greater than ½ inch within 18 inches of the release mechanism (figure 13).
11. Where a **wall of a dwelling** serves as part of the barrier, one of the following should apply:
- (a) **All doors with direct access to the pool** through that wall should be equipped with an **alarm** which produces an audible warning when the door and its screen, if present, are opened. Alarms should meet the requirements of *UL 2017 General-Purpose Signaling Devices and Systems, Section 77*. For more details on alarms, see page 13.
 - (b) The pool should be equipped with a **power safety cover** which complies with ASTM F1346-91 listed below.
 - (c) Other means of protection, such as **self-closing doors with self-latching devices**, are acceptable so long as the degree of protection afforded is not less than the protection afforded by (a) or (b) described above.
12. Where an **above ground pool structure is used as a barrier** or where the barrier is mounted on top of the pool structure, and the means of access is a ladder or steps (figure 8a), then
- (a) **the ladder** to the pool or steps should be capable of being secured, locked or removed to prevent access (figure 8b), or
 - (b) **the ladder or steps should be surrounded by a barrier** (figure 8c). When the ladder or steps are secured, locked, or removed, any opening created should not allow the passage of a 4 inch diameter sphere.

For more information on

Fencing:

- **ASTM F 1908-08** *Standard Guide for Fences for Residential Outdoor Swimming Pools, Hot Tubs, and Spas*: <http://www.astm.org/Standards/F1908.htm>
- **ASTM F 2286-05** *Standard Design and Performance Specifications for Removable Mesh Fencing for Swimming Pools, Hot Tubs, and Spas*: <http://www.astm.org/Standards/F2286.htm>

Covers:

- **ASTM F 1346-91** *Standard Performance Specification for Safety Covers and Labeling Requirements for All Covers for Swimming Pools, Spas and Hot Tubs*: <http://www.astm.org/Standards/F1346.htm>

Note: ASTM Standards are available for a fee. You may want to contact a pool contractor.

And:

- **ASTM Standards**, contact ASTM online at: <http://www.astm.org/CONTACT/index.html>
- **UL** (Underwriters Laboratories) Relevant Pool and Spa Standards <http://www.ul.com/global/eng/pages/>, look for Life Safety and Security Product



CPSC's **Pool Safely: Simple Steps Save Lives campaign** provides advice and tips on drowning and entrapment prevention. Installing barriers is just one of the *Pool Safely* Simple Steps for keeping children safe around all pools and spas. Here are others:

Rule # 1: Never leave a child unattended around a pool, spa, bath tub, or any body of water.

At pools, spas, and other recreational waters:

- Teach children basic water safety skills.
- Learn how to swim and ensure your children know how to swim as well.
- Avoid entrapment by keeping children away from pool drains, pipes, and other openings.
- Have a phone close by at all times when visiting a pool or spa.
- If a child is missing, look for them in the pool or spa first, including neighbors' pools or spas.
- Share safety instructions with family, friends, babysitters, and neighbors.

If you have a pool:

- Install a 4-foot fence around the perimeter of the pool and spa, including portable pools.
- Use self-closing and self-latching gates; ask neighbors to do the same if they have pools or spas.
- If your house serves as the fourth side of a fence around a pool, install and use a door or pool alarm and/or a pool or spa cover.
- Maintain pool and spa covers in good working order.
- Ensure any pool or spa you use has anti-entrapment safety drain covers; ask your pool service representative if you do not know.*
- Have life saving equipment such as life rings, floats or a reaching pole available and easily accessible.

**The Virginia Graeme Baker Pool & Spa Safety Act, a federal law, requires all public pools and spas to have anti-entrapment drain covers and other devices, where needed. Residential pools are not required to install these but it is recommended that they do so.*

Visit **www.PoolSafely.gov** for more information. See CPSC's latest submersion reports: *Submersions Related to Non-pool and Non-spa Products, 2012* and *Pool and Spa Submersion Report, 2012*.

Figure 5 : Distance of horizontal structures on a pool fence

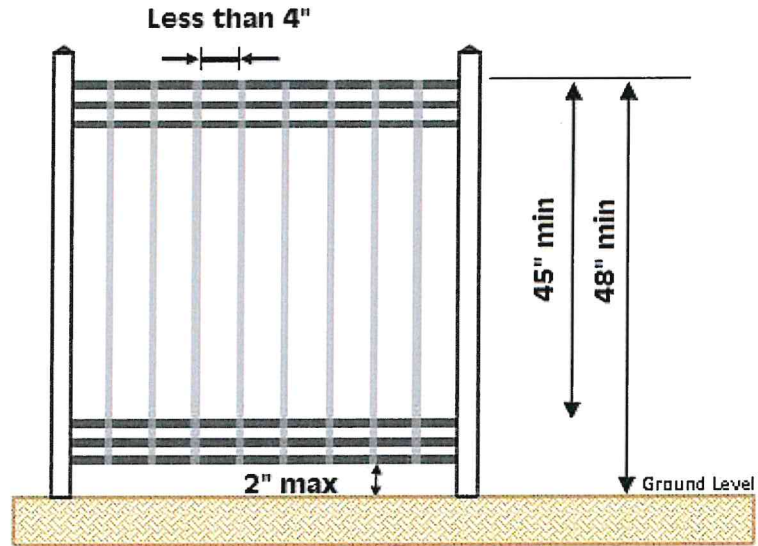
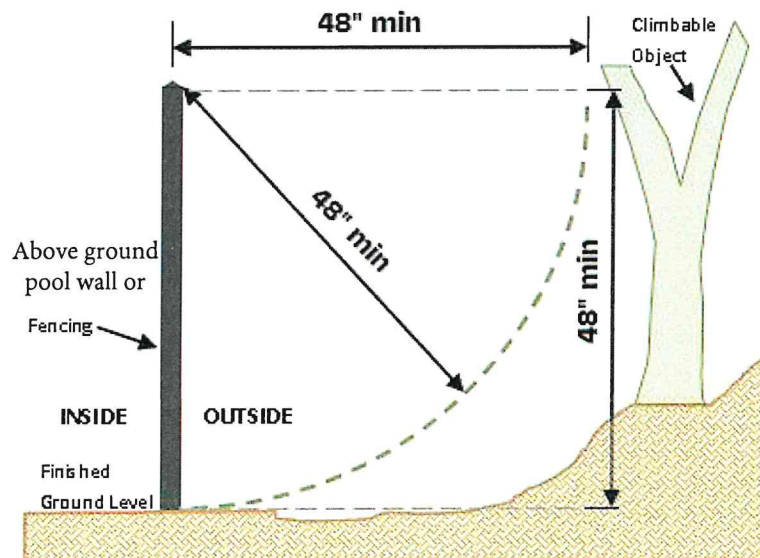
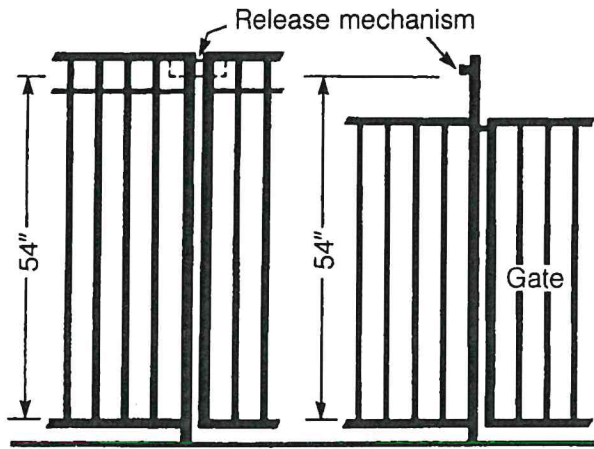
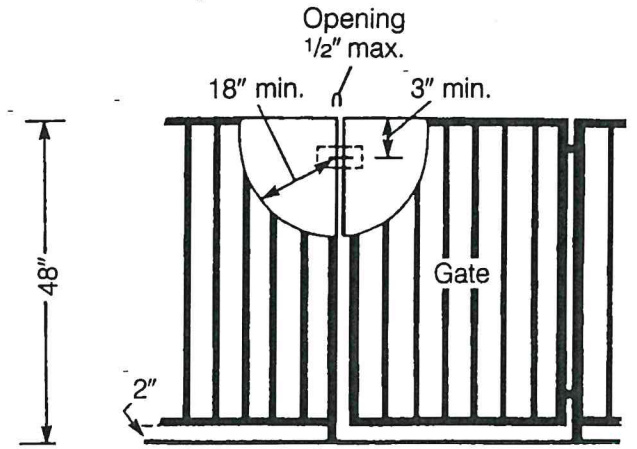

Figure 6: Method for determining distance of objects from the pool fence





The release mechanism shall be located at 54" or higher from the bottom of the gate.



The release mechanism shall be located less than 54" from the bottom of the gate.

Other gates must be equipped with self-latching devices. The self-latching devices must be installed as described for pedestrian gates.

SWIMMING POOL, SPA, AND HOT TUB PERMIT PACKET

Any swimming pool or hot tub **capable** of being filled with **24 inches** or more of water, must obtain a building permit and must have a safety barrier meeting the requirements below whether portable, inflatable or permanent (see *Figure 1 and 2*).

All pool requirements are now in the 2015 International Swimming Pool and Spa Code.

ABOVE GROUND SWIMMING POOLS

All inflatable / storable swimming pools require a safety barrier (See safety barrier information for in-ground swimming pools for detailed requirements.)

The side walls of permanent above ground swimming pools and portable pools constructed of PVC pipe and have a flat surface (*Figure 2*) may be used as the safety barrier upon meeting the following requirements:

1. The pool walls must be a minimum of 48 inches in height measured on the outside of the pool.

Note: If the pool is installed into or on a hill side, the grade must be cut back so that no part of the grade is within 48 inches of the top of the pool. A compliant fence or guard must be installed around the perimeter of the pool if it is closer than 48 inches to grade. The opening between the barrier and top of the pool must not exceed 4 inches (Detail 3).

2. A removable or a swing up and locking stairs must be used for access into the pool (*Figures 1, 2 and 3*) and must be labeled in accordance with Section 705 (Attachment 1.)
3. The pool pump and filter shall be set back a minimum of 3 feet from the pool walls.

Permit application notes: Provide height or pool to top of walls and information of grade where pool will be installed (level or hillside), provide picture or pamphlet of ladder and stairs and indicate what label will be installed on them.

IN GROUND SWIMMING POOLS

A safety barrier (fence and/or building walls) must completely enclose the pool area (*Figure 4*) and comply with the following:

1. Safety barrier must be a minimum of 4 feet in height measured from the outside.
2. When horizontal members of the barrier are greater than 45 inches apart the maximum opening of vertical members may be less than 4 inches. When horizontal members are less than 45 inches apart, the maximum opening between vertical members may be 1-3/4 inches (*Detail 1*).
3. Openings in chain link fence shall be maximum 2-1/4 inch (*Detail 2*).
4. The maximum opening between the bottom of fence and the grade is 2 inches (*Detail 1*).

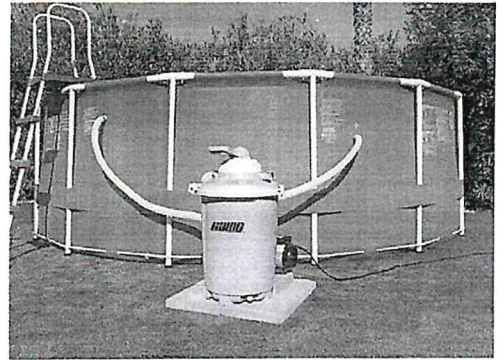

Figure 1. A permit is required for a portable framed swimming pool with PVC piping, however, the pool walls may be used as the safety barrier if the following requirements are met:

1. Pool walls are a minimum of 48" in height from grade to the top of pool rail.
2. Ladder is removable or capable of being folded up and locked in the up position. Include label on ladder.



Figure 2. A permit and safety barrier is required for an inflatable or portable swimming pool. The pool walls cannot be used as the safety barrier. The safety barrier for these types of pools must comply with those requirements for an in-ground swimming pool.



Figure 3. Ladder/stairs that are capable of being swung up and locked into position so that the safety barrier is in place while the pool is not in use. Include label on ladder.

All gates shall swing in the direction away from the pool area (swing out) and self-close and self-latch.

Release mechanisms at gates shall comply with one of the following:

1. The release mechanism must be located a minimum of 54 inches in height measured from the grade below (Figure 5).
2. The release mechanism must be located on inside part of the gate a minimum of 3-inches down from the top. In addition, there must be a barrier with openings no greater than 1-2 inch within 18-inches in all directions from the release mechanism (**Exception:** the barrier does not have to continue past the top of the gate.) (Figure 6)

The following requirements must be followed when a building wall is part of the safety barrier:

1. All door and window openings with a sill height less than 48 inches from the floor must be alarmed with a pool guard alarm listed and labeled in accordance with UL 2017 (Figure 7).
2. The alarm deactivation switch must be located a minimum of 54 inches in height measured from the floor. (Figure 7) The pool guard alarm is NOT a typical motion or home security alarm. (**Exception:** An alarm is not required at door openings when the pool is equipped with a power cover that meets ASTM F 1346 Standard.)

Barrier Exception: A safety barrier is not required if the swimming pool has a power safety cover complying with ASTM F 1346.

In most cases, an in-ground swimming pool will be filled with water prior to backfill. In some cases, the concrete around the pool and safety barrier (fence) cannot be installed until the backfill is complete. This creates a situation when the pool is filled without the required safety barrier. Strong consideration should be placed on installing the safety barrier before the pool is filled. If it is infeasible to install the permanent barrier without first filling the pool, a temporary safety barrier meeting all the above requirements shall be installed.

Permit application notes: Provide the following information for a permit to show the safety barrier requirements will be met:

1. Property or survey of the pool area showing it will be completely enclosed by a fence and/or building walls.
2. Picture or pamphlet of the fence indicating the height and spacing of horizontal and vertical members and opening between the grade and bottom of the fence.
3. Information regarding the gates and release mechanisms.
4. Information regarding the doors and alarms at door and window openings in building walls.

ABOVEGROUND SWIMMING POOLS W/DECKS

A safety barrier (fence and/or building walls) must completely enclose the pool and/or deck area and comply with the following:

1. Safety barrier must be a minimum of 4 feet in height measured from the outside. When a gate at the top of stairs for a deck is part of the safety barrier, the measurement is taken from the last stair if the gate is flush with edge of the floor. If the gate is not flush with the edge of the floor the measurement is taken from the floor level. (Figure 8)



Figure 4. Inground swimming pool completely enclosed by fencing.

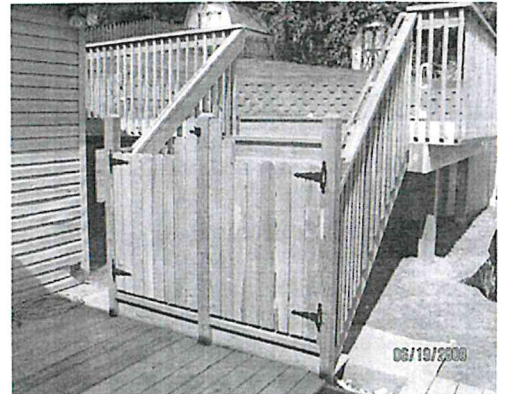

Figure 5. Release mechanism located at 54" above grade. Gate and handrails are a minimum of 48" in height at all locations. Maximum of 2" between bottom of gate and stair.



Figure 6. Release mechanism located 3" (min) down from top, inside of gate at bottom of stairs (photo is showing 12" from the top). Safety barrier with maximum 1/2" openings is within 18" of all directions of the release.

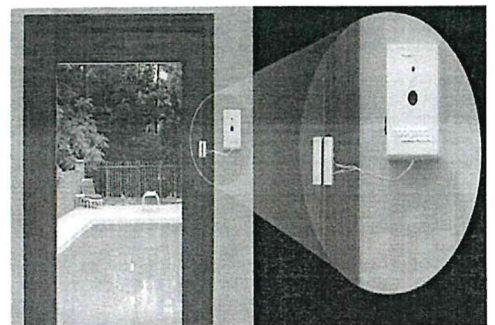

Figure 7. Pool guard alarm listed and labeled in accordance with UL 2017. Minimum 54 inches in height. Must be on all doors and windows with a sill height less than 48 inches above the floor in exterior walls used as part of the barrier to pool areas.

- When horizontal members of the barrier are greater than 45 inches apart the maximum opening of vertical members may be less than 4 inches. When horizontal members are less than 45 inches apart, the maximum opening between vertical members may be 1-3/4 inches.
- The maximum opening between the bottom of a fence or gate and grade is 2 inches. (Detail 1)

All gates shall swing in the direction away from the pool and/or deck area (swing out) and self-close and self-latch regardless if it is located at the top or bottom of stairs to a deck.

Release mechanisms at gates shall comply with one of the following:

- The release mechanism must be located a minimum of 54 inches in height measured from the grade below (Figure 5).
- The release mechanism must be located on inside part of the gate a minimum of 3 inches down from the top. In addition, there must be a barrier with openings no greater than 1/2 inch within 18 inches in all directions from the release mechanism (Exception: the barrier does not have to continue past the top of the gate.) (Figure 6).

When the gate for stairs leading to a pool deck are located at the bottom (grade level) it must comply with the following:

- Guardrails along both sides of the stairs and gate itself must be a minimum of 48 inches in height measured on the outside. (Figures 5 and 6)
- The gate must meet the safety barrier requirements for spacing of horizontal members and vertical openings. (Detail 1)
- The gate must swing outward and meet the requirements for release mechanisms.

The following requirements must be followed when a building wall is part of the safety barrier:

- All door and window openings with a sill height less than 48 inches in height from the floor must be alarmed with a pool guard alarm listed and labeled in accordance with UL 2017. (Figure 7)
- The alarm deactivation switch must be located a minimum of 54 inches in height measured from the floor. (Figure 7) The pool guard alarm is NOT a typical motion or home security alarm. (Exception: An alarm is not required at door openings when the pool is equipped with a power cover.)

Permit application notes: Provide the following information for a permit to show the safety barrier requirements will be met:

- Property or survey of the pool area showing it will be completely enclosed by a protected deck, fence and/or building walls.
- Picture or detail of the fence and guardrails (when required to meet safety barrier opening requirements) indicating the height and spacing of horizontal and vertical members and opening between the gate and deck floor and/or grade and bottom of the fence.



Figure 8. Gate at top of stairs. Safety barrier measurement for the gate (48 inches minimum height) is taken from the last stair if gate is flush with edge of deck floor or is taken from the floor if gate is not flush with edge.

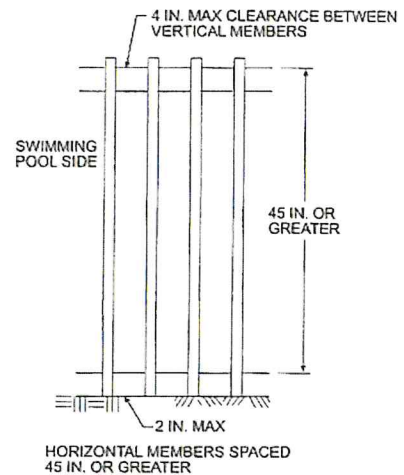

For St: 1 inch = 25.4 mm.

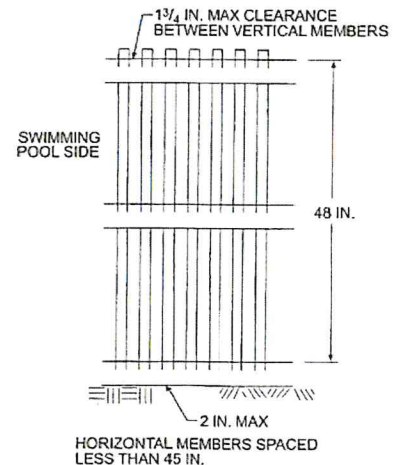

Detail 1. Figure AG-105.2(2) Private Swimming Pool Barrier Construction

3. Information regarding the gates and release mechanisms.
4. Information regarding the doors and alarms at door and window openings in building walls.
5. Deck construction details. (See "Residential Deck and Deck Roof Guide" for deck requirements.)

HOT TUBS

Hot tubs must have a safety cover that complies with ASTM F 1346. **Permit application notes:** Provide copy of pamphlet of hot tub and cover indicating it complies with ASTM F 1346. There should be a label on the cover showing ASTM F1346 standard compliance.

SWIMMING POOLS WITH HEATERS

Heaters shall be equipped with a readily available on-off switch and shall not have continuously burning pilot lights.

Pools heated to temperatures greater than 90 degrees shall have pool cover with a minimum insulation value of R-12.

Permit notes: Provide copy of pamphlet indicating heater and covers comply.

See permit checklist for more information

See

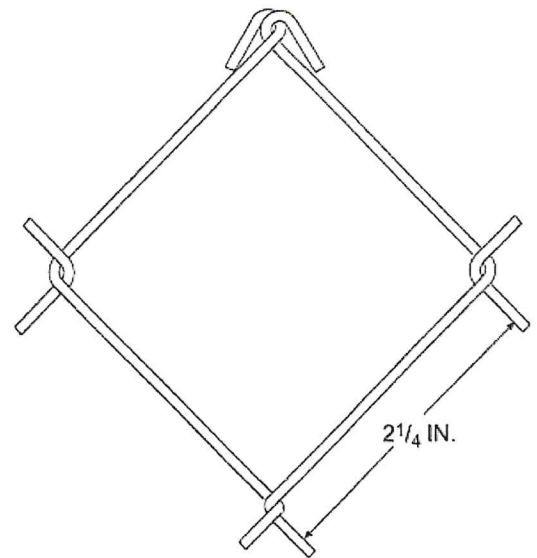

Detail 2. Figure AG-105.2(3) Chain-Link Fence Mesh for Private Swimming Pools

ATTACHMENT 1

SECTION 705 SAFETY SIGNS

705.1. Signs to be installed prior to final inspection. Safety signage such as "NO DIVING" signs and other safe use instruction signs that are provided by the pool and ladder manufacturer shall be posted in accordance with the manufacturer's instructions prior to final inspection.

- ❖ It is not enough that the pool manufacturer supplies the safety signage. The signs are only effective when they are posted.

705.2 Safety signs for ladders. Safety signage for ladders shall be in accordance with Sections 705.2.1 through 705.2.3.2.

- ❖ Advisements on how to use each type of ladder are necessary to encourage safe use and significantly reduce the potential for accidents.

705.2.1 A-frame ladders. Safety signage for A-frame ladders shall be in accordance with Sections 705.2.1.1 through 705.2.1.4.1. The words on the signage shall be readable by persons standing in the pool and standing outside of the pool as applicable for the required location of each sign.

- ❖ Signage has to be readable by the pool users who are about to use the ladders. This could mean that some signs would have to be facing a user who is in the pool.

705.2.1.1 No diving warning. A-frame ladders shall have the following words posted on the in-pool side of the ladder and on the pool entry side of the ladder: "NO DIVING." The location of the words shall be above the elevation of the design water level of the pool.

- ❖ The designated entry and exits point(s) of an on ground storable pool are the best locations to warn the user that diving is prohibited. Children frequently attempt to dive from a ladder as it is the easiest way to climb above the water surface.

705.2.1.2 Entrapment warning. A-frame ladders shall have the following words posted on the pool side of the ladder: "TO PREVENT ENTRAPMENT OR DROWNING DO NOT SWIM THROUGH, BEHIND, OR AROUND LADDER."

- ❖ Even though A-frame ladders are either designed to reduce entrapment or are equipped with blocking material and means to reduce entrapment, users still need to be warned to stay away from A-frame ladders while swimming.

705.2.1.3 Type A, A-frame ladders. Type A double access A-frame ladders shall have the following words posted on the ladder: "REMOVE AND SECURE LADDER WHEN POOL IS NOT OCCUPIED."

- ❖ The Type A ladder is made to be removed to limit access to the pool. The signage reminds the responsible person to remove the ladder.

705.2.1.4 Type B, A-frame ladders. Type B limited access A-frame ladders shall have the following words posted on the ladder: "SECURE LADDER WHEN POOL IS NOT OCCUPIED."

- ❖ The Type B ladder is made to be "secured" to limit access to the pool. "Secured" means to close off with the ladder manufacturer-supplied cover or blocking mechanism to limit access to the pool. The signage

reminds the responsible person to "secure" the ladder.

705.2.1.4.1 Swing up or slide up secured ladders. Type B limited access A-frame ladders that utilize swing-up or slide-up sections for limiting access to the pool shall have the following words posted on the ladder as applicable for the type of securing method:

1. "WHEN POOL IS NOT OCCUPIED, SWING UP AND SECURE."
 2. "WHEN POOL IS NOT OCCUPIED, LIFT OFF."
 3. "WHEN POOL IS NOT OCCUPIED, SLIDE UP AND SECURE."
- ❖ Some Type B ladders are made having "swing up," "lift off" or integral sliding cover capability. Specific signage is required for those special types of Type B ladders.

705.2.2 Type C staircase ladders. Type C staircase ladders that swing up to limit access to the pool or that are removed to limit access to the pool shall have the following words posted on the ladder: "WHEN NOT IN USE SWING UP AND SECURE OR REMOVE."

- ❖ Some Type C ladders are "swing up" or removal types. Special signage is required for those types where the ladder is the primary access limitation for the pool.

705.2.3 Type D in-pool ladder. Safety signage for Type D in-pool ladders shall be in accordance with Sections 705.2.3.1 and 705.2.3.2. The words on the signage shall be readable by persons standing in the pool or standing outside the pool as applicable for the required location of each sign.

- ❖ Signage has to be readable by the pool users who are about to use the ladders. This could mean that some signs would have to be facing a user who is in the pool.

705.2.3.1 No diving warning. Type D in-pool ladders shall have the following words posted on the in-pool side of the ladder and on the pool entry side of the ladder: "NO DIVING." The location of the words shall be above the elevation of the design water level of the pool.

- ❖ The designated entry and exit point(s) of an on ground storable pool are the best locations to warn the user that diving is prohibited. Children frequently attempt to dive from a ladder as it is the easiest way to climb above the water surface.

705.2.3.2 Entrapment warning. Type D in-pool ladders shall have the following words posted on the ladder: "WARNING: TO PREVENT ENTRAPMENT OR DROWNING, DO NOT SWIM THROUGH, BEHIND, OR AROUND LADDER."

- ❖ Even though Type D ladders are designed to reduce entrapment or are equipped with blocking material and means to reduce entrapment, users still need to be warned to stay away from ladders while swimming.